

## V-Arrangement Light Curtain Quickstart Guide

Mounting set BT 700.5M-2SET

# Installation

## Required materials

1. Pair of light curtain transmitter and receiver of the CML 700i series
2. 2 pieces mounting bracket set BT 700.5M-2SET (3x from 1.5 m light curtain length)
3. Wrench for hexagon head screw M6 x 10
4. Mounting material and tool for the mounting brackets in the measuring scene

## Montage

1. Mount the mounting brackets on the light curtain transmitter with 2 M6 x 10 screws  
→ Ensure that the black screen is oriented correctly!
2. Mounting of the light curtain receiver on the mounting brackets with 2 M6 x 10 screws  
→ Connection sides of transmitter and receiver must be on the same side!  
→ Black screen of transmitter and receiver must face the measurement line!
3. The ends of transmitter and receiver have to flush.
4. Tighten the 4 M6 x 10 screws
5. Mounting the two mounting brackets via the T-slot holes in the measuring scene  
→ Transmitter and receiver must be parallel to the conveyor level!

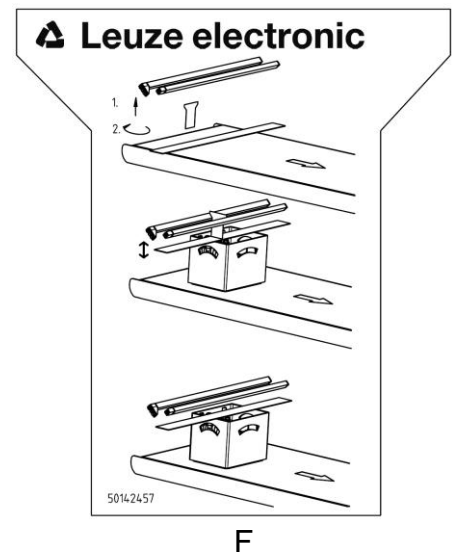
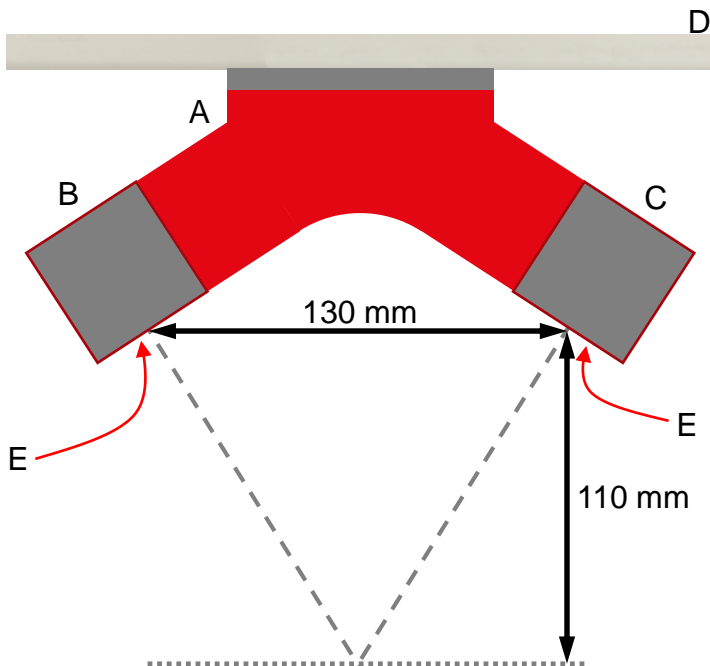

- A – Mounting bracket
- B – Light curtain transmitter
- C – Light curtain receiver
- D – Mounting base
- E – Black screens of transmitter and receiver
- F – Alignment template

1. Electrical connection of the light curtain according to the manual
2. Switching on the light curtain
3. Align the fixing device D using the template F according to the printed pictograms
4. **Teach-In of the light curtain**  
 → Teaching at the control panel of the receiver

Level 0	Level 1	Level 2	Description
Main Settings	Commands		Teach    Reset    Factory settings

↗ Select Main Settings > Command > Teach.  
 ↗ Press the ↵ button to execute the teach.

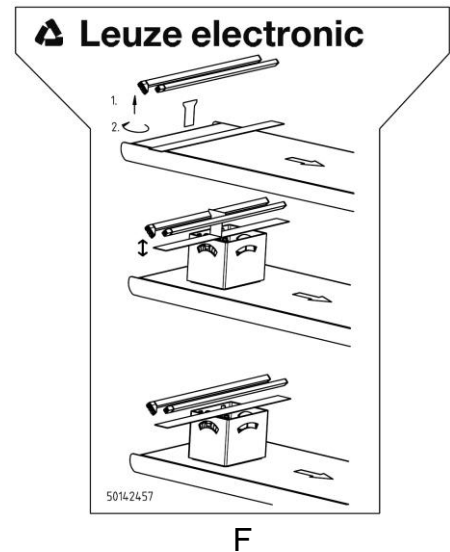
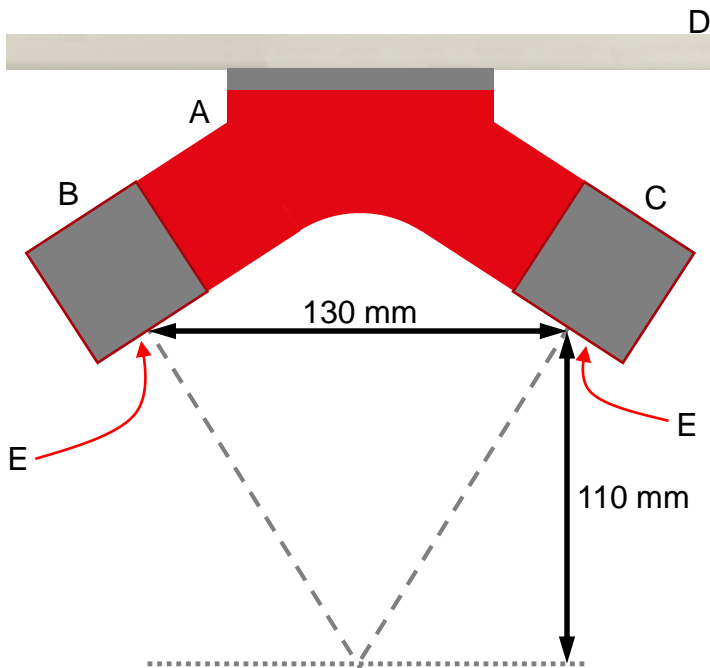

- A – Mounting bracket
- B – Light curtain transmitter
- C – Light curtain receiver
- D – Mounting base
- E – Black screens of transmitter and receiver
- F – Alignment template